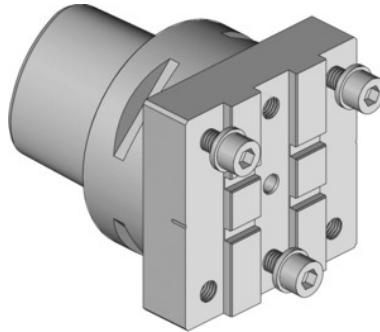

Garant**Modular toolholder, Type: PSC63****Order data**

| | |
|--------------|---------------|
| Order number | 319135 PSC63 |
| GTIN | 4045197781031 |
| Item class | 31V |

Description**Advantage:**

Precisely adjustable tip height, permitting ideal machining results with consistent tool life. Turret misalignments can be compensated.

Length L: 63 mm

Width B: 63 mm

Height H: 38 mm

suitable for parting-off blade holder: Type 1

Technical description

| | |
|---------------------------------------|------------------------|
| Width B | 63 mm |
| Height H | 38 mm |
| Length L | 63 mm |
| suitable for parting-off blade holder | Type 1 |
| Type of product | Grooving insert holder |

